

Design optimisation of ring elements for broadband reflectarray antennas

N. Misran, R. Cahill and V.F. Fusco

Abstract: Plane wave scattering from a flat surface consisting of two periodic arrays of ring elements printed on a grounded dielectric sheet is investigated. It is shown that the reflection phase variation as a function of ring diameter is controlled by the difference in the centre resonant frequency of the two arrays. Simulated and measured results at X-band demonstrate that this parameter can be used to reduce the gradient and improve the linearity of the reflection phase versus ring size slope. These are necessary conditions for the re-radiating elements to maximise the bandwidth of a microstrip reflectarray antenna. The scattering properties of a conventional dual resonant multilayer structure and an array of concentric rings printed on a metal backed dielectric substrate are compared and the trade-off in performance is discussed.

1 Introduction

A microwave reflectarray is a compact low profile antenna, consisting of a grounded flat array of resonant conducting elements and a primary source. A plane wavefront is created by controlling the scattering properties of the individual microstrip patches, which are designed to give a progressive reflection phase shift across the aperture [1]. This type of antenna combines many of the best features of arrays and conventional reflectors. For example, spatial feeding eliminates the design complexity associated with conventional microstrip fed arrays and can reduce the dielectric absorption and ohmic losses responsible for reducing the gain of these antennas particularly at high frequencies. The main disadvantage of the reflectarray is the limitation on the available bandwidth, which is imposed by varying the dimensions of each re-radiating element about its nominal resonant size. This is the simplest method available to control the reflection phase; however, the phase versus microstrip patch size slope is typically very large and non-linear at the extremities [2]. The former implies that tight fabrication tolerances are necessary to achieve the desired phase value, and the latter property restricts satisfactory operation to a narrow band of frequencies. A thick substrate can be employed in the design to reduce the phase slope; however, as the Q factor decreases so does the total phase range. Ideally, values from 0° to 360° should be available from the elements in a reflectarray, so a reduction in the phase range is detrimental to the pattern performance of this class of antenna.

Encinar [3] has exploited the dual resonant response of a two-layer grounded array of dissimilar size patch elements to overcome the limitations associated with the use of thick substrates. In that work, a linear response was achieved over an 8% bandwidth from a five-layer sandwich structure

consisting of a ground plane, two spacers, and two periodic arrays with a constant stacked patch size ratio. This design excludes the possibility of obtaining dual frequency operation since independent control of the dimensions of the two patches is normally required in each unit cell [4].

This paper considers a building block for a simpler and more versatile architecture where the reflection phase is controlled by varying the diameter of resonant rings. Such elements are widely employed as frequency selective surfaces (FSS) [5]. First, the electromagnetic behaviour of a two-layer grounded ring array (Fig. 1a) is studied, since the elements in the two screens are weakly coupled and essentially yield independent reflection coefficients [6]. It is shown that the rings can be nested (Fig. 1b) and printed on to a single planar surface to give the required dual resonant response. This structure is a superior alternative to other broadband element designs that have been reported because the periodic array can be printed on a single surface, eliminating the need for double side mask alignment. This makes construction of the antenna very much simpler and cheaper, and makes broadband dual frequency operation from a multilayer structure possible. However, the phase range obtainable from a grounded concentric ring screen is shown to be limited by the minimum required physical separation of the elements. The transmission line matrix (TLM) [7] method has been used to study the scattering behaviour of the periodic ring arrays, and the results at X band are shown to be in close agreement with waveguide simulator measurements [8].

2 Phase response of ring elements

Design methodology

Periodic arrays of conductive ring elements on close packed square or triangular lattices have frequency selective properties that have been exploited for a wide range of terrestrial antenna and space instrument applications [9]. The filter response of these frequency selective surfaces (FSS) is largely determined by the element diameter and periodicity, and the electrical properties and thickness of the backing substrate. The transmission and reflection bands of simple ring arrays are generally widely spaced with an edge of band frequency ratio (where the loss is less than 0.5 dB)

© IEE, 2003

IEE Proceedings online no. 20030857

doi:10.1049/ip-map:20030857

Paper first received 23rd January and in revised form 16th June 2003. Online publishing date: 22 October 2003

The authors are with High Frequency Electronics Laboratories, School of Electrical and Electronic Engineering, Queen's University Belfast, Ashby Building, Stranmillis Road, Belfast BT9 5AH, N. Ireland, UK

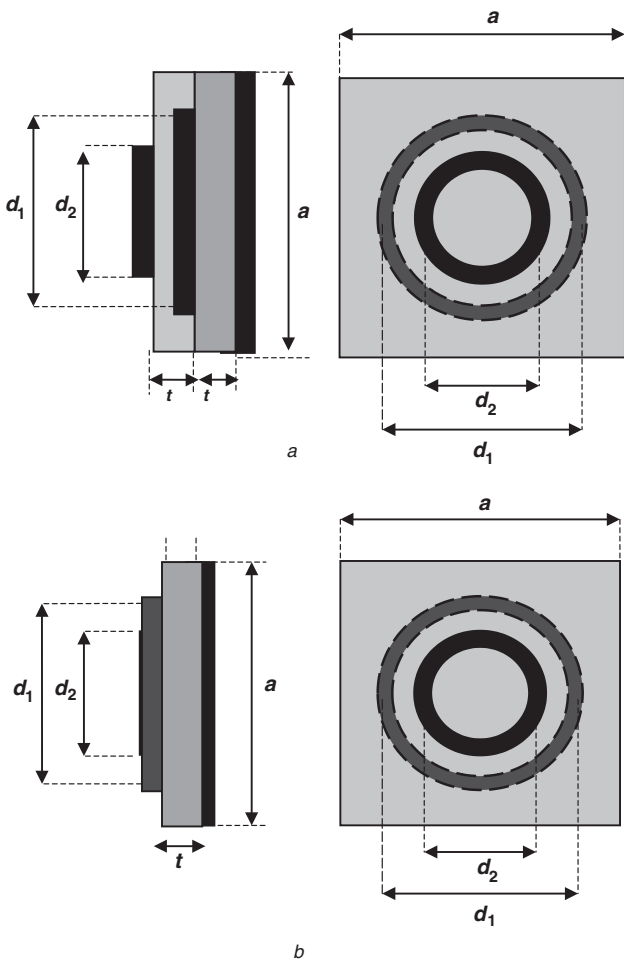

Figure 1 Periodic cell of reflectarray ring element
a Grounded two-layer stacked ring array structure
b Grounded concentric ring array structure
 $t = 1.524\text{ mm}$, $a = 10\text{ mm}$, d_1 and d_2 are variables, $\epsilon_r = 3.54$, $\tan\delta = 0.0018$

of 2.5:1 or more [5]. Planar arrays of printed concentric rings [10] have a usable passband between the resonances, which are generated by the individual rings, and for these elements the band spacing can be as small as 1.2:1. Higher Q filtering where the passband and rejection band spacing is less than 1.07:1 has been achieved by making use of the interference effects between two or more screens of simple ring elements [11]. Generally a trade-off must be established between the polarisation purity, Q factor, bandwidth, sensitivity to angle of incidence, and the onset of grating lobes. However, for a given application, well established design rules can be invoked to optimise the physical layout of the periodic array.

A reflectarray is simply a printed FSS with a ground plane on the opposite surface of the substrate; therefore, this can be designed to give broadband performance by controlling the frequency response of the array in the same way as a FSS. Broadbanding of the reflectarray elements has been investigated by analysing the complex scattering parameters of a unit cell consisting of one or more co-located resonant rings separated from the ground plane by a dielectric wafer. In this way, the infinite array model [1] can be used to establish the relationship between the diameter of the rings and the phase of the reflected energy. For this study, the transmission line matrix (TLM) package MICROSTRIPES V5.5 [7] (MICROSTRIPES is a trade mark software product by FLOMERICS) was used to model the response of the structures at X band. The three-

dimensional mesh was graded manually with a minimum size of 0.005λ in the region close to the array where the fields are highest. To reduce the run-time, symmetry was exploited and only one quarter of the unit cell was meshed, and an infinite array created using suitable boundary conditions. The excitation port was located $\lambda/4$ above the elements and the detection port was located on the surface of the ground plane, which served as the phase reference for the S_{11} predictions. Frequencies swept simulations of the infinite array were performed by setting a zero cut-off frequency in the waveguide structure, and therefore modelling was performed at normal incidence where the largest unattainable phase range has been shown to occur [12].

Double layer ring reflectarray elements

Figure 1*a* shows the configuration of the double layer ring sandwich structure, which consists of two periodic arrays, two dielectric spacers and a ground plane. The 0.4 mm wide conducting loops are centred on a 10 mm square lattice, and the screens are separated from each other and the ground plane by 1.524 mm thick dielectric substrate layers of permittivity $\epsilon_r = 3.54$ and $\tan\delta = 0.0018$. TACONIC [13] material with these values was used to provide experimental verification of the computed results. The ratio of the upper and lower ring diameters (U/L), d_2 and d_1 in Fig. 1*a*, was selected to be 0 (upper ring removed), 0.8, 0.93 and 1 (upper and lower ring sizes the same). Computed plane wave reflection phase coefficients for TE normal incidence are shown in Fig. 2, where the lower ring diameter is varied between 4.0 mm and 6.6 mm. To provide a useful comparison, the curves in Fig. 2 have been plotted at the frequency of resonance (f_0) for a lower ring diameter of 5.4 mm, and relative to the 180° reflection phase obtained from a perfect conductor. The results suggest that the interlayer coupling factor is small since scattering from the upper ring changes the resonant frequency by less than

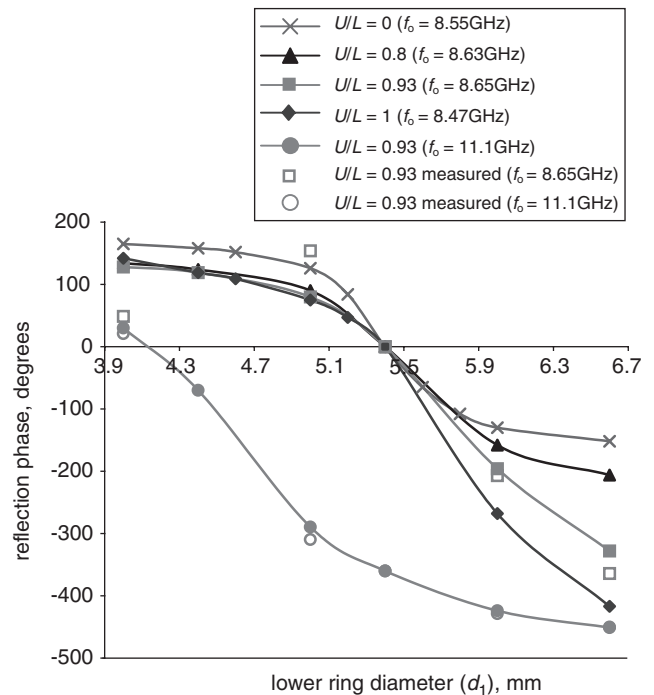

Figure 2 Computed and measured reflected phase of grounded two-layer stacked ring array structure
 Upper ring diameter/lower ring diameter (U/L)
 Resonance frequency (f_0)

100 MHz about the nominal value of 8.55 GHz for the single embedded ring ($U/L=0$). For the upper ring, the effective permittivity of the substrate is lower, and therefore at this frequency a second resonance occurs when the loop diameter is 6.4 mm. Figure 2 shows that, in the range where both rings are capacitive (3.9–5.4 mm), the size of the upper ring has little effect and the reflection response is non-linear with a phase range less than 150° . When the diameter of the lower ring is larger than 5.4 mm the element is inductive, but the upper ring is capacitive below its resonant diameter of 6.4 mm. Therefore, between these values the equivalent circuit of the two-layer periodic screen is simply a shunt LC circuit. At 8.5 GHz, a second resonance (360° in Fig. 2) is generated when the size of the lower ring is 8 mm and 6.4 mm for U/L values of 0.8 and 1 respectively. The significance of this is clear from Fig. 2, which shows that the linear phase range of the slope between the two resonances is critically dependent on the difference in the physical size of the lower ring at these two positions. For example, Fig. 2 shows that when $U/L=0.8$ the phase range is less than 200° , and the non-linear response is similar to a single embedded element ($U/L=0$). However, when the diameter of the two rings are identical ($U/L=1$), the curve is linear over a phase range which exceeds the 360° needed to provide a practical reflectarray design [1]. When the U/L parameter is reduced slightly to 0.93, the phase slope is less steep, and therefore this array design is less sensitive to manufacturing tolerances.

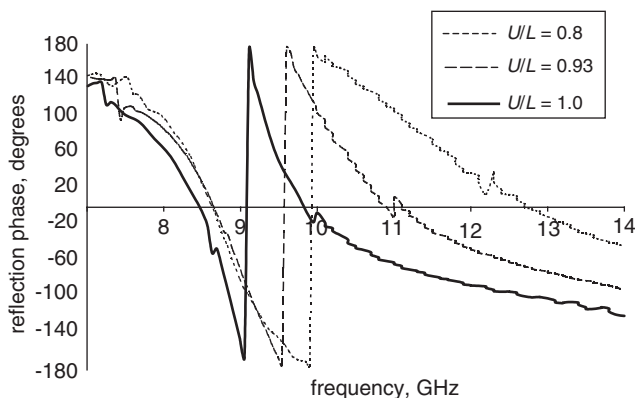

Figure 3 Computed frequency dependent reflection phase response of grounded two-layer stacked ring array at normal incidence ($d_1 = 5.4$ mm)

The scattering behaviour of the stacked rings can be explained by observing the predicted swept frequency reflection phase coefficients of the three arrays. This is shown in Fig. 3 relative to a perfect conductor where, for each U/L parameter value, the lower ring diameter is 5.4 mm. These results can be mapped to those plotted in Fig. 2 if it is assumed that the permittivity of the dielectric is independent of frequency and also within the computed band the variation in electrical thickness does not modify the reflection phase values. In Fig. 3 the phase variation is similar in the range up to 9 GHz and 10 GHz for U/L values of 1 and 0.8 respectively, since, as shown in the TLM model, the surface current is confined mostly to the lower ring. However, at higher frequencies the phase variation results mainly from current excitation in the upper ring and as a consequence can be tailored by choosing the relative size of the upper element. For a U/L value of 0.93, the gradient is less steep than a stacked ring arrangement where the diameters are identical ($U/L=1$). A further decrease in the phase gradient can be achieved when the separation of

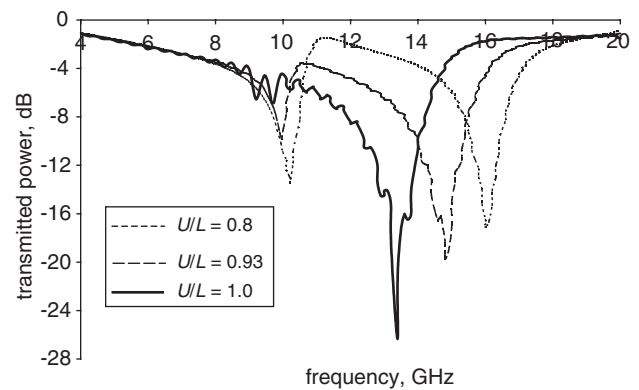

Figure 4 Computed frequency dependent transmission response of two-layer stacked ring array without ground plane at normal incidence ($d_1 = 5.4$ mm)

the two resonances increases further, as shown in Fig. 3 for the element configuration $U/L=0.8$. However, between the resonant points (8.6 GHz and 12.7 GHz) in the range 9.5–10 GHz, the phase slope reduces since the current amplitude in both rings is very low. This is shown in Fig. 4, where the periodic structure is around 80% transmissive (at 11 GHz) between the resonant frequencies, which are shifted upwards when the ground plane is removed. This explanation is consistent with the formation of a plateau in the phase plot in Fig. 2 for diameters 6 mm to 6.6 mm; however, beyond this range, the reflection phase converges rapidly to 360° when the lower ring diameter is 8 mm. Clearly the ratio of the stacked ring diameters is an important design parameter which can be used to minimise the phase gradient without compromising the linearity of the response curve.

Concentric ring planar structure

A double resonant response can also be obtained from a concentric ring FSS where the conductive loops are nested and printed on to a single surface [10]. The advantage of this approach is that the reflectarray structure can be constructed simply by photo-etching the array pattern on one side of a conductivity coated dielectric substrate. Moreover, broadband dual frequency operation may be achieved by replacing the single ring elements in the five-layer sandwich structure described in the previous section with concentric rings.

The critical design driver for multilayer reflectarrays is the relative size of the stacked elements, since this determines the separation of the two resonant frequencies. A U/L ring diameter ratio of 0.93 was shown to provide a suitable response for broadband applications by resonating at frequencies around 8.5 GHz and 11.0 GHz. The grounded concentric ring array design shown in Fig. 1b behaves like a perfectly conducting screen at the same two frequencies when the inner to outer ring diameter ratio is $I/O=0.8$, therefore this reflectarray element might be expected to give a linear phase variation similar to the one shown for $U/L=0.93$ in Fig. 2. However, the computed results in Fig. 5 show that the reflection phase change is small when the element size is increased from 7.0 mm to 8.0 mm. Two other geometries were analysed with inner to outer ring diameters $I/O=0.71$ and 0.86, which are excited at similar resonant frequencies to the double layer structure with parameter values $U/L=0.8$ and 1 respectively.

A comparison between the results in Figs. 2 and 5 shows that it is not possible to achieve a linear response over a phase range $>330^\circ$ from a concentric ring array by simply mapping the resonant frequencies of the two reflectarray

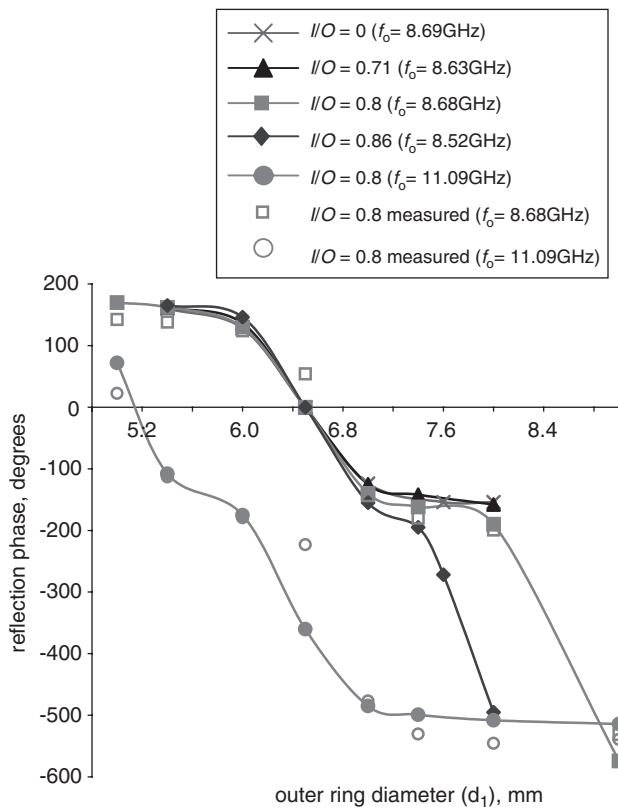

Figure 5 Computed and measured reflected phase of grounded concentric ring array structure
Inner ring diameter/Outer ring diameter (I/O)
Resonance frequency (f_0)

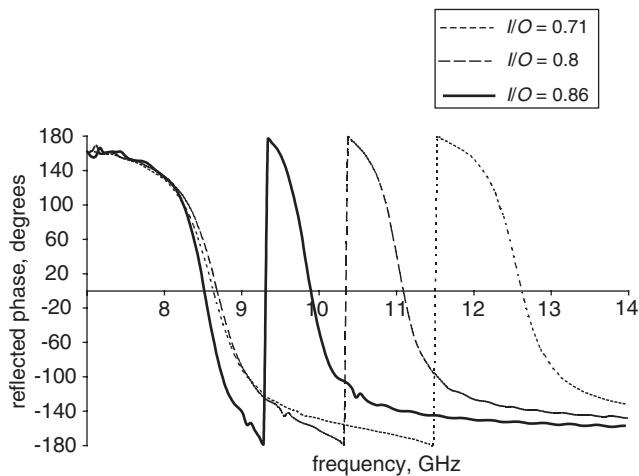

Figure 6 Computed frequency dependent reflection phase response of grounded concentric ring array at normal incidence ($d_1 = 6.5$ mm)

structures. Although the swept frequency plots in Figs. 3 and 6 show that the phase variation is similar around the first resonance (8.5 GHz), the response of the inner and top rings is very different. For example, the computed results in Fig. 6 show that the Q factor of the concentric rings is larger because of the formation of a wide region between the two resonant frequencies where the phase slope is significantly reduced (-120° to -180°). Removing the ground plane and observing the transmission coefficients (Fig. 7) of the FSS confirms that each array is almost completely transmissive over a range of frequencies which increases when the parameter value I/O decreases. Again, this behaviour is consistent with the results plotted in Fig. 5, where the

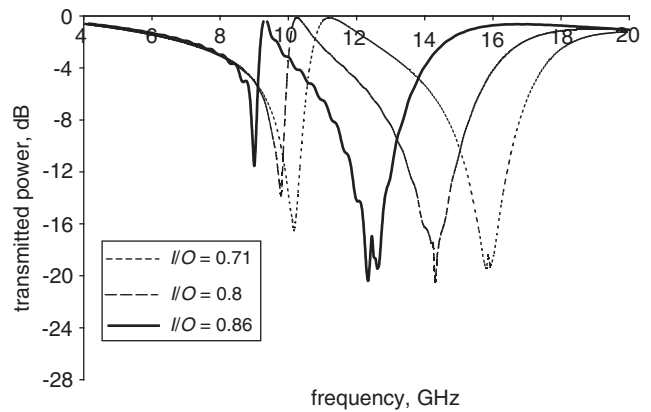

Figure 7 Computed frequency dependent transmission response of concentric ring array without ground plane at normal incidence ($d_1 = 6.5$ mm)

plateau is formed in the region where the periodic array is weakly excited. Improving the linearity of the phase versus element size plots requires modification of the classical transmission coefficients of the concentric ring array to remove or narrow the passband peak between the two rejection bands plotted in Fig. 7. Clearly this can be achieved by reducing the separation between these two bands; however, in a practical design this is difficult to implement because of the need to avoid contact between the conductive tracks of the nested rings. For example, in our computer model, the gap is only 0.34 mm for the $I/O = 0.86$ design, where the ring conductor width is reduced from 0.4 mm to 0.2 mm. A limitation on the broadband performance obtainable from elements printed on thick substrate material is therefore imposed by the physical inability to accommodate the nested rings.

3 Measured results

A series of waveguide simulator measurements was used to validate the simulated scattering parameters of the reflectarray elements. By inserting just a few unit cells across the rectangular aperture of a waveguide it is possible to measure the reflection phase of an infinite grounded rectangular array of rings of a given size [8]. The resonant frequency of the testpieces, and phase variation with element size, were measured using a VNA, which provided the reflection phase relative to a metal sheet which served as a reference plane in the S_{11} test set-up. The electromagnetic behaviour of the reflectarray element in the TE plane is identical to the scattering that occurs in the waveguide when a TE_{10} wave impinges on the testpiece; however, in the waveguide the angle of incidence is dependent on frequency. A standard WR-90 waveguide adapter was connected to a 200 mm long tapered waveguide with a rectangular output section of dimensions 100 mm \times 30 mm \times 10 mm. For this waveguide size the angle of incidence varies [8] between 35° and 27° over the measurement frequency range 8.5 GHz to 11.1 GHz. The ring patterns of the double layer array were printed on opposite sides of a 1.524 mm thick $\epsilon_r = 3.54$, $\tan\delta = 0.0018$ TACONIC RF-35-600 substrate, and a second laminate with copper deposited on one side only provided the ground plane and spacer as shown in Fig. 1a. The two substrates were clamped together around the edges by nylon screws to remove air gaps and mounted in the 30 mm \times 10 mm rectangular waveguide aperture, which could accommodate three closely packed rings, thus ensuring insensitivity to angle of incidence effects [5] which was confirmed using a Floquet modal technique [9]. The

three unit cells containing the concentric rings were simply printed on one side of the 1.524 mm thick copper-coated substrate as shown in Fig. 1b.

In Fig. 2, experimental and simulated results at two frequencies are plotted for a double layer ring array with a U/L value of 0.93. At 8.65 GHz, the input transition to the waveguide simulator is close to its cut-off frequency, nevertheless good correlation is demonstrated in the linear region of the plot at and beyond the 5.4 mm resonant diameter of the embedded rings where the reflectarray antenna design data is obtained. This reflectarray element configuration is predicted to give a similar response at 11.1 GHz, since at this frequency (f_0) the resonant diameter of the upper ring is 5 mm. In Fig. 2 measurements that were performed at this frequency, which is well above the waveguide cut-off, are in closer agreement with the computed results in both the linear region of the plots and the non-linear range, where both rings are inductive. Note that in Figs. 2 and 5 the experimental phase data points have been shifted by 180° to enable the shape of the plots to be more easily compared. The equivalent difference in the resonant frequency (or conversely, the resonant ring size at the measurement frequency) can be attributed to the prediction accuracy of the TLM computer model. Measured and numerical data for a concentric ring array with an inner to outer diameter ratio of $I/O = 0.8$ are compared in Fig. 5. The results confirm the existence of a small plateau region centred at 7.5 mm where there is incomplete reflection from the periodic array.

4 Conclusions

It has been shown that the bandwidth of a reflectarray antenna can be increased by exploiting the scattering properties of a dual resonant periodic array of printed rings above a ground plane. The ability to control the linearity and Q factor of the reflection phase response has been demonstrated by varying the diameter ratio of a stacked double ring resonant element. To avoid non-linearity in the phase plot, it is necessary for the periodic array to be strongly excited over the full range of ring diameters used in the reflectarray design, and for this to occur the individual resonances must be closely spaced. For a given dielectric thickness, this imposes a limit on the gradient reduction obtainable. The optimum performance for the stacked arrangement described in this paper is obtained when the resonant frequency of the upper ring is approximately 1.28 times higher than the lower ring. For a given periodicity, smaller elements generate a narrower reflection band and the implication of this is an increase in the resonant Q factor of the array and hence the phase slope. However, for a stacked arrangement this is

compensated for by the larger separation between the ground plane and the upper ring, and therefore independent control of the Q factor is obtainable for the two rings. A dual resonant periodic array of nested rings has also been shown to provide a broadband response with a linear phase range in excess of 330° at normal incidence. This is an attractive option because of the simplicity of printing the array on a single surface, and furthermore by stacking two screens it should be possible to provide an independent and controllable broadband phase response at two frequencies. However, for optimum performance, the resonant frequency of the concentric rings must be closer than the two rings in the stacked arrangement, since as shown in Figs. 4 and 7 the frequency selective properties of the periodic elements are quite different.

5 Acknowledgments

This work was funded by the UK EPSRC under grant no. GR/R15139/01 and GR/R54996/01. N. Misran is supported by a studentship from the Universiti Kebangsaan Malaysia. The authors acknowledge the support provided by Dr Rachid Aitmehdi of Flomerics.

6 References

- Pozar, D.M., Targonski, S.D., and Syrigos, H.D.: 'Design of millimeter wave microstrip reflectarrays', *IEEE Trans. Antennas Propag.*, 1997, **45**, (2), pp. 287–295
- Pozar, D.M.: 'Analysis of a reflectarray antenna using microstrip patches of variable size', *Electron. Lett.*, 1993, **29**, (8), pp. 657–658
- Encinar, J.A.: 'Design of two-layer printed reflectarrays using patches of variable size', *IEEE Trans. Antennas Propag.*, 2001, **49**, (10), pp. 1403–1410
- Encinar, J.A.: 'Design of a dual frequency reflectarray using microstrip stacked patches of variable size', *Electron. Lett.*, 1996, **32**, (12), pp. 1049–1050
- Cahill, R., and Parker, E.A.: 'Crosspolar levels of rings in reflection at 45° incidence: influence of lattice spacing', *Electron. Lett.*, 1982, **18**, (24), pp. 1060–1061
- Misran, N., Cahill, R., and Fusco, V.F.: 'Reflection phase response of microstrip stacked ring elements', *Electron. Lett.*, 2002, **38**, (8), pp. 356–357
- MICROSTRIPES, FLOMERICS, www.flomerics.com, accessed September 2002
- Hannan, P.W., and Balfour, M.A.: 'Simulation of a phased-array antenna in waveguide', *IEEE Trans. Antennas Propag.*, 1965, **13**, (3), pp. 342–353
- Vardaxoglou, J.C.: 'Frequency selective surfaces – analysis and design' (John Wiley, Research Studies Press Ltd, 1997)
- Cahill, R., and Parker, E.A.: 'Concentric rings and Jerusalem cross arrays as frequency selective surfaces for a 45° incidence diplexer', *Electron. Lett.*, 1982, **18**, (8), pp. 313–314
- Antonopoulos, C., Cahill, R., Parker, E.A., and Sturland, I.M.: 'Multilayer frequency selective surfaces for millimetre and submillimetre wave applications', *Proc. IEE Microw. Antennas Propag.*, 1997, **144**, (6), pp. 415–420
- Sze, K.Y., and Shafai, L.: 'Phase properties of single-layer patch arrays with applications to line-source-fed microstrip reflectarrays', *Proc. IEE Microw. Antennas Propag.*, 2002, **149**, (1), pp. 64–70
- TACONIC Advanced Dielectric Division www.taconic-add.com, accessed September 2002